

System Diagram

SURFACE MOUNT TYPE (LOW VOLTAGE)

BI-POLAR

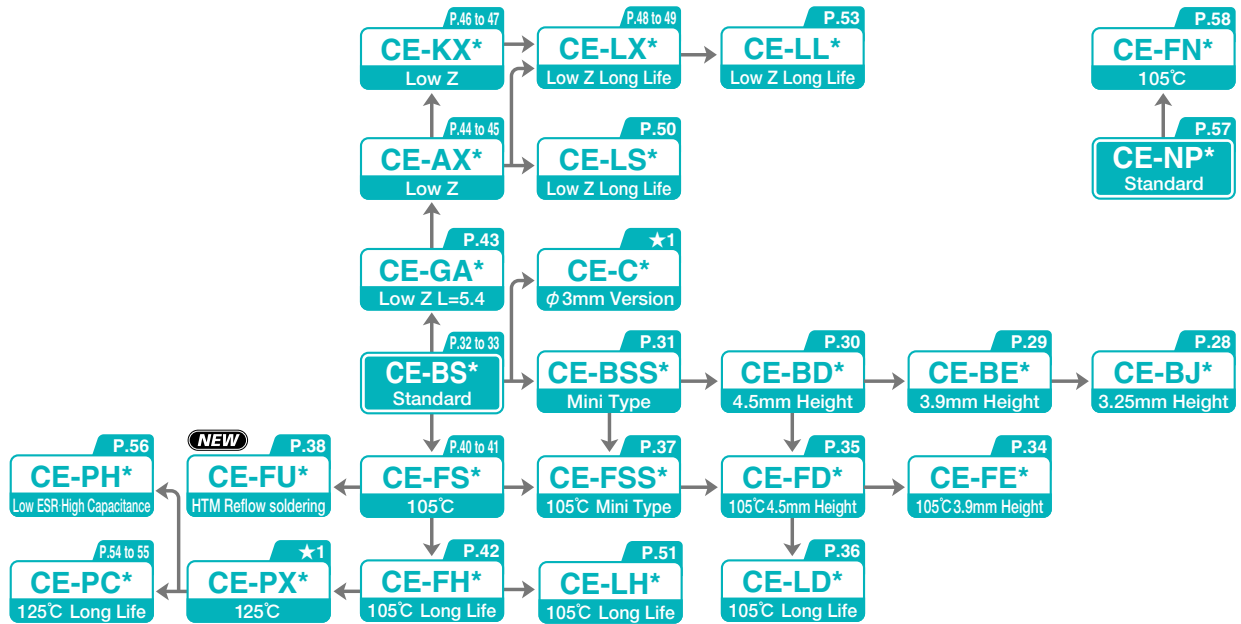

RADIAL LEAD TYPE (LOW VOLTAGE)

BI-POLAR

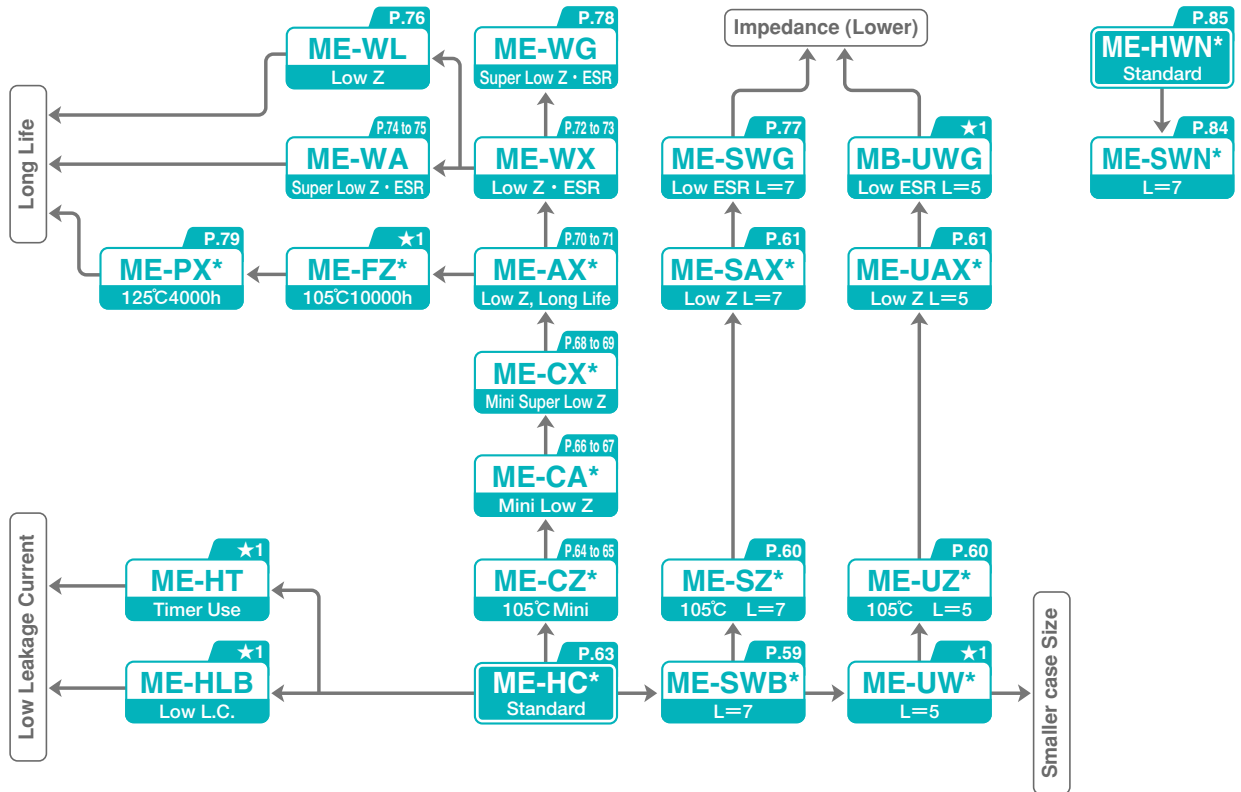

Please refer to <http://www.sunelec.co.jp> for the information in columns where

★1 marking is indicated in a page row.

*solvent proof

System Diagram for Power supply

FOR SECONDARY SMOOTHING CIRCUIT

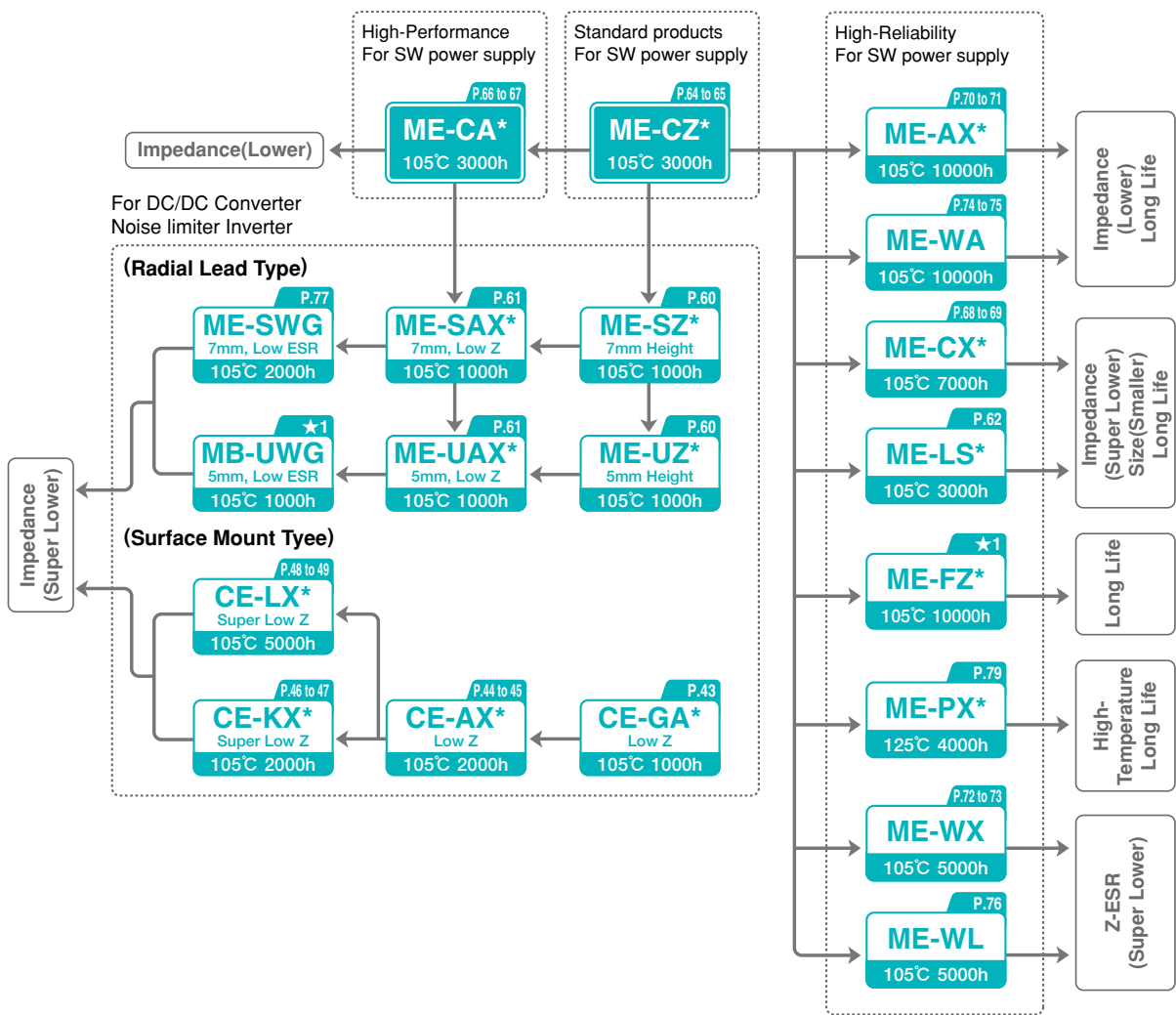

FOR PRIMARY SMOOTHING CIRCUIT (MID. & HIGH VOLTAGE)

